

MODEL: RCD-1.5FSN2 + P-N23DNA
 RCD-1.5FSN2 + P-N23DWA
 (P0111x-02)

NO.	PART NAME	REPLACEMENT PART		Q'TY PER UNIT	SUMMARY	UNIT VOLTAGE CATEGORY										CATEGORY CODE	VOLTAGE (V)	FREQUENCY(HZ)	PHASES
		DRAW. NO.	ORDER NO.			Z													
U04	FUSE	17C90851A	P27957	1	5A FOR CONTROL CIRCUIT	Z													
U14	CAPACITOR	17C56791F	P23345	1	4MF 440VAC	Z													
U15A	THERMISTOR	17B24544M	P22447	1	THM1 AIR INLE	Z										Z	220-240	50	1
U15B	THERMISTOR	17B24544N	P23317	1	THM2 AIR OUTLET	Z													
U15C	THERMISTOR	17C74419G	P22437	1	THM3 FREEZE PROTECTION	Z													
U15D	THERMISTOR	17H05298A	P28301	1	THM5 GAS	Z													
U21	EXP. VALVE	17G57447A	P24990	1		Z													
U31	AIR FILTER	17B25334A	P23337	1	FOR AIR PANEL	Z													
U34	AIR GRILLE	17B25379M	P28464	1	FOR P-N23DNA (WITH AIR FILTER)	Z													
		17B25379G	P23811		FOR P-N23DWA (WITH AIR FILTER)	Z													
U36	FAN RUNNER	17A10444A	P23316	1		Z													
U41	HEAT EXCHANGER	17B31737A	P25117	1		Z													
U65	PLASTIC MATERIAL	17G37440B	P23408	8		Z													
U71A	MOTOR	17G38973A	P23287	1	FAN MOTOR 35W	Z													
U71B	MOTOR	17C61918A	P22780	1	FOR DRAIN DISCHARGE MECHANISM	Z													
U71C	MOTOR	17G87149A	P27359	1	FOR AIR PANEL SWING MOTOR ASS'Y	Z													
U82	TRANSFORMER	17B26061A	P23449	1		Z													
U85A	PRINTED CIRCUIT BOARD	17G87759E	P27277	1	MAIN PCB	Z													
U85B	PRINTED CIRCUIT BOARD	17B34589A	P26262	1	FOR NOISE PROTECTION	Z													
U85C	PRINTED CIRCUIT BOARD	17G34856C	P23448	1	PULSE WIDTH MODULATION	Z													
U87	FLOAT SW	17G34946A	P22428	1		Z													

- Notes:
1. Refer to page D-RCD-1.5FSN2-Z for the location of the listed parts.
 2. The replacement part drawing number marked "" is different from that of the unit part. Change the setting for this unit, if required.

Location of Spare Parts in The Air Panel (Optional)

MODEL: RCD-1.0FSN2
 RCD-1.5FSN2
 RCD-2.0FSN2
 RCD-2.5FSN2
 RCD-3.0FSN2
 and
 P-N23DNA
 P-N23DWA

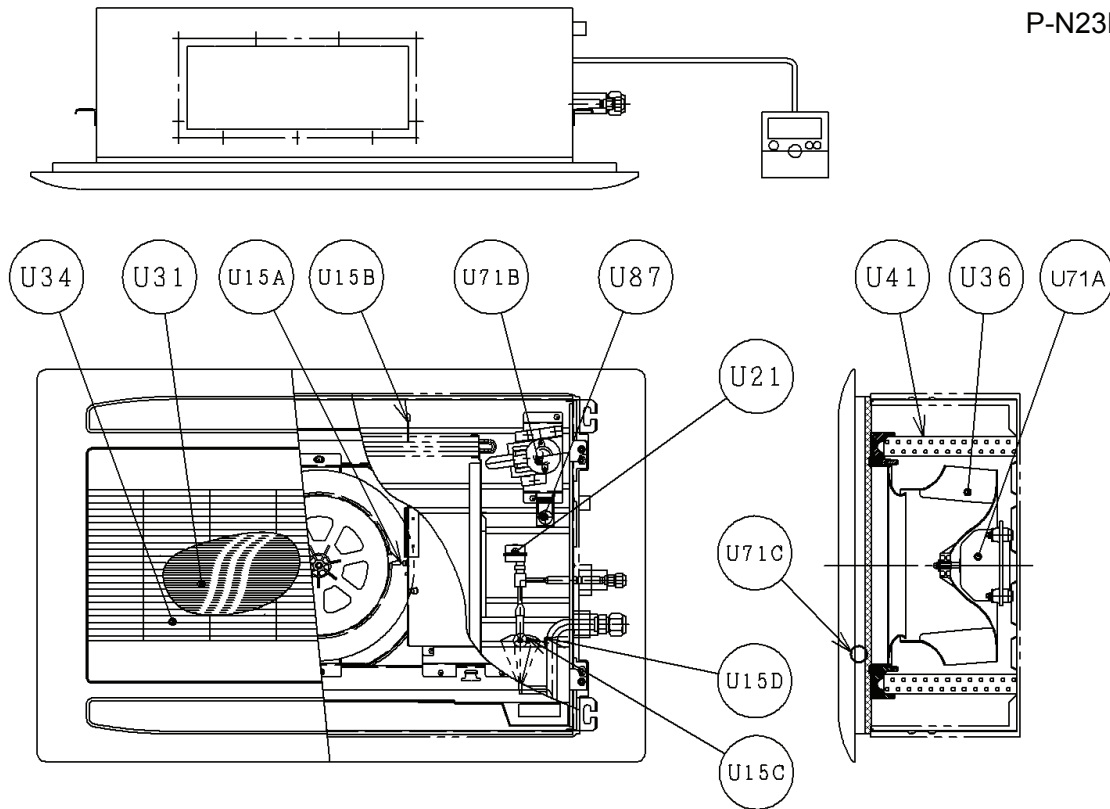

Location of Electrical Equipment in The Electrical Box

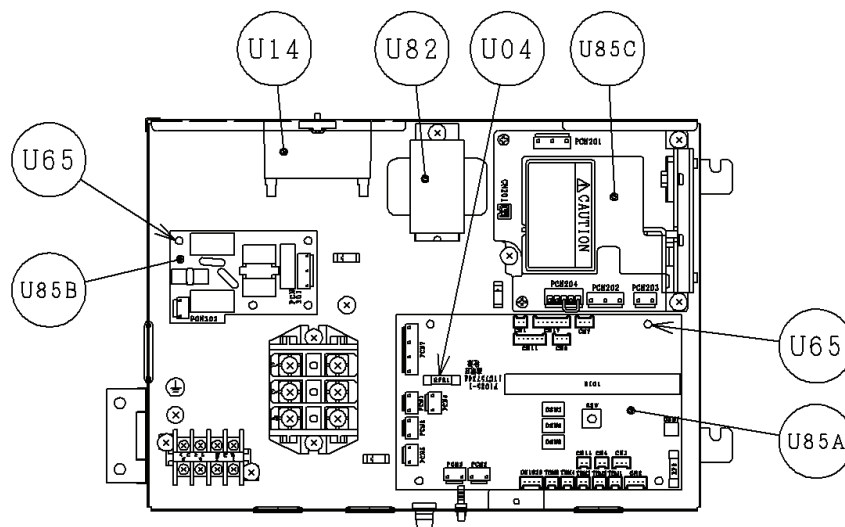

D-RCD-1.0FSN2-Z, D-RCD-1.5FSN2-Z, D-RCD-2.0FSN2-Z, D-RCD-2.5FSN2-Z, D-RCD-3.0FSN2-Z